



Gocator®

ADVANCING QUALITY AND PRODUCTIVITY WITH 3D SENSOR TECHNOLOGY

CONTENTS

3 WHAT WE DO

- 4 GOCATOR. IT'S BETTER TO BE SMART.
- 5 INTELLIGENCE RUNS IN THE FAMILY
- 6 THE DEFINITION OF FACTORYSMART™ INSPECTION
- 8 THE GOCATOR ECOSYSTEM - MORE THAN JUST A SENSOR

10 SMART 3D ACQUISITION

- 11 CORE 3D SCANNING TECHNOLOGIES

12 INTUITIVE AND INTEGRATED USER EXPERIENCE

- 13 SIMPLE SETUP
- 14 ADVANCED CONNECTIVITY
- 15 OPTIMAL EXPOSURE SETTINGS
- 16 GOCATOR EMULATOR
- 17 GOCATOR ACCELERATOR

18 ROBUST MEASUREMENT

- 19 SPEED AND PRECISION
- 20 POWERFUL BUILT-IN TOOLS
- 21 PROFILE MEASUREMENT
- 22 3D SURFACE MEASUREMENT
- 23 REAL-TIME VISUALIZATION
- 24 3D + 2D FUSION

25 MAXIMUM CONTROL

- 26 TRIGGER MODE
- 27 TOTAL SENSOR CONTROL
- 28 FLEXIBLE INPUT/OUTPUT

29 REVOLUTIONARY EXTENSIBILITY

- 30 DUAL SENSOR SYSTEMS
- 31 MULTI-SENSOR NETWORKING
- 32 SOFTWARE DEVELOPMENT KIT (SDK)
- 33 GOCATOR DEVELOPMENT KIT (GDK)

34 THE LMI ADVANTAGE

WHAT WE DO

Gocator is our labor of love. We have a dedicated research and development team that takes every factor into consideration when designing the Gocator: from product design, to user experience, to the quality of the output data.

SPEED. PRECISION. PERFORMANCE.

1 COMPACT FOOTPRINT FOR SMALL SPACE AND ROBOT ARM DEPLOYMENT

2 RUGGED IP67 CONSTRUCTION FOR THE HARSHTEST INDUSTRIAL ENVIRONMENTS

3 BUILT-IN DATA PROCESSING PUTS THE SMART IN GOCATOR 3D SMART SENSOR



4 FACTORY PRE-CALIBRATED OPTICS AND TEMPERATURE STABLE MOUNTING DELIVER HIGHLY ACCURATE, REPEATABLE RESULTS RIGHT OUT OF THE BOX

5 RICH I/O FOR COMMUNICATING WITH YOUR HARDWARE AND CHOOSING HOW YOU TRIGGER AND SCAN



GO-CATOR
IT'S BETTER
TO BE SMART.

INTELLIGENCE RUNS IN THE FAMILY

Gocator all-in-one 3D smart sensors are trusted worldwide for automated inline inspection.

SCAN, MEASURE & CONTROL

Gocator combines 3D scanning, measurement and control in a single device, with no external PCs or controllers required. This efficient design paired with high-performance functionality makes Gocator easy to integrate into existing inspection systems—minimizing system cost and maximizing product quality and throughput.

All Gocator sensors are factory pre-calibrated so users can immediately set up the sensor via a web browser and configure functions such as exposure, triggering logic, dimensional measurement tools and communication method.

Once setup is complete, simply disconnect the computer, and the Gocator runs standalone delivering high-speed, micron-level measurements in real-time for a wide variety of critical inspection applications.

Gocator is available in a wide selection of models suited to your exact application.



COMPLETE 3D INSPECTION. BUILT-IN.

Gocator leverages both laser triangulation and fringe pattern projection. These technologies provide optimal 3D scanning for both high speed and stationary 3D part inspection.

THE DEFINITION OF FACTORYSMART® INSPECTION



WEB ENABLED

- Built-in web server, no separate software required
- Use a standard web browser for setup and control
- Easy-to-use, intuitive, multi-language interface
- View real-time data on any computer, any OS

APPLICATION READY

- Built-in measurement tools, no coding necessary
- Easy setup allows real 3D measuring in minutes, not days
- Tag and track parts for sorting and rejecting defects right from the sensor
- Use as a single sensor, dual sensor system, or scale up to a network of sensors
- Measure profiles or volumes and detect surface patterns all with the same sensor

FLEXIBLE

- Available in single point profile, line profile and snapshot technologies
- Choice of 2M, 3R, and 3B laser classes
- Open source SDK for custom application development
- Gocator Development Kit (GDK) for custom firmware development
- Emulator for simulation of pre-recorded data sets
- Leverage the power of a PC with the Gocator Accelerator



HIGH PERFORMANCE

- Scan rates up to 32,000 Hz
- Micron resolution with large field of view
- Gigabit Ethernet real-time data delivery
- Refer to datasheets for specifications for each model

FACTORY PRE-CALIBRATED

- Delivers real world coordinates, right out of the box
- Highly accurate assembly process for consistent, reliable, and precise measurement

RICH I/O

- Interface to your existing control systems, including PLCs and robots
- Interface with your existing control systems, including PLCs
- Choose how you want to trigger and scan
- Select Ethernet, digital, analog, and/or serial data output

COMPACT FOOTPRINT

- Easily fits into small spaces
- Can be used on robotic arms
- Fits your application without costly modifications

#FactorySmart®

MORE THAN JUST A SENSOR



Gocator[®]
ECOSYSTEM

THERE'S A COMPLETE INSPECTION ECOSYSTEM INSIDE EVERY GOCATOR.

Gocator is the ultimate inspection platform—masterfully combining **3D data acquisition, measurement and control** with revolutionary **extensibility** and a fully **integrated user experience**.

Anchoring

Single Point Profile

Snapshot

Line Profile





SMART 3D ACQUISITION

CORE 3D SCANNING TECHNOLOGIES

POINT PROFILE SENSORS

Laser Distance Profile Triangulation

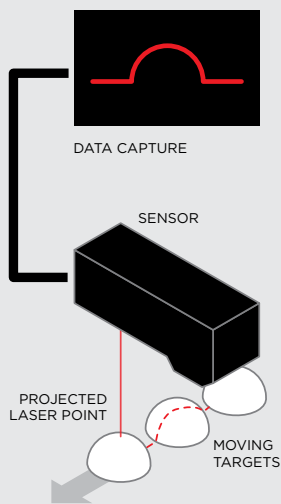

A NEW CLASS OF LASER ONLY FROM LMI

Gocator Point Profile Sensors are high speed (32 kHz) single point measurement devices capable of profiling along the direction of part travel or inspecting displacement in a fast moving process. Ideal for contour feature measurement of parts moving at very high speed or closed-loop feedback systems, these point profilers are unique all-in-one solutions for a wide variety of applications.

LINE PROFILE SENSORS

Laser Line Profile Triangulation

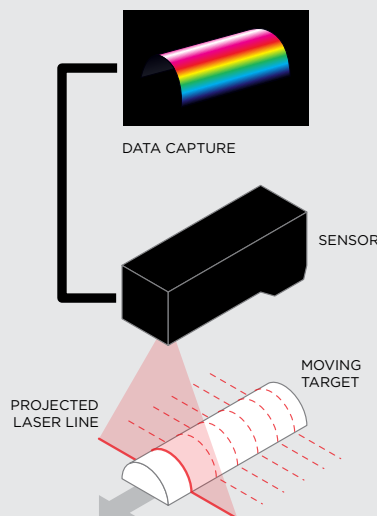

THE ORIGINAL 3D SMART SENSOR

Gocator Line Profile Sensors measure a cross sectional shape. Cross sections can be collected to form 3D point clouds representing discrete whole parts. A profile sensor can measure shape of very small (10 mm) to large width objects (1.5m) moving at high speed. Profilers can simultaneously output calibrated 2D intensity images for use with common 2D imaging libraries for surface inspection.

SNAPSHOT SENSORS

Stereo Full-Field Structured Light

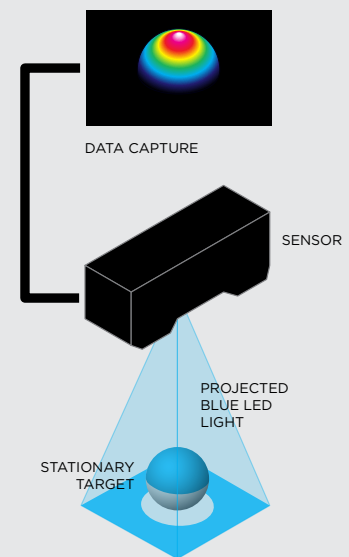

WORLD'S FIRST ALL-IN-ONE SNAPSHOT SENSOR

Gocator Snapshot Sensors are the first family of 3D smart sensors to combine full-field 3D point cloud acquisition using fringe projection with 3D measurement tools for specific 3D features. These sensors are ideal for inline inspection applications where objects are momentarily stationary like in robot inspection or pick and place.

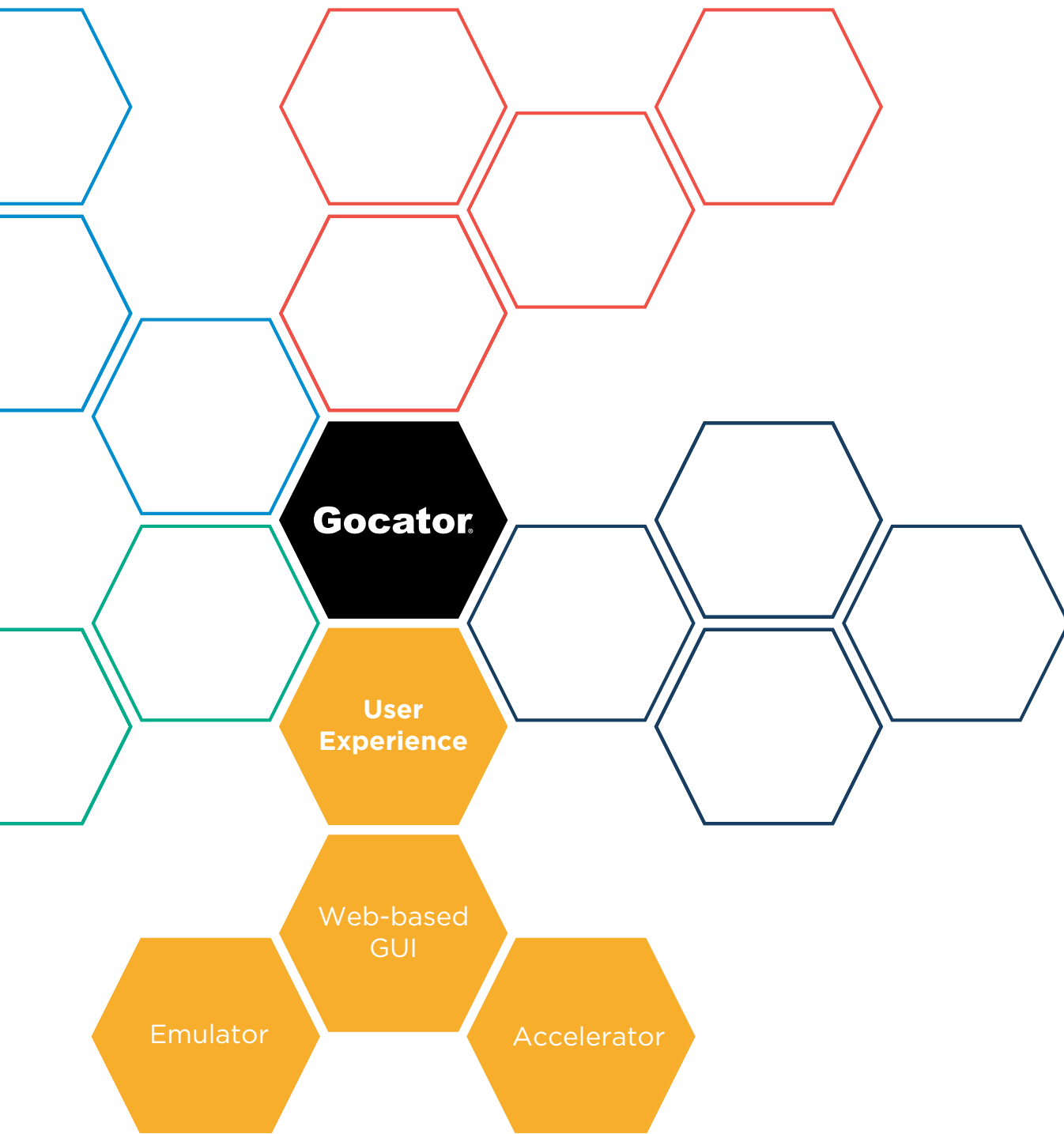

INTUITIVE AND INTEGRATED USER EXPERIENCE

SIMPLE SETUP

Setting up your Gocator is fast, easy and trouble free.

- Use your favorite web browser to access and control the Gocator
- Multi-language ready for non-English speakers to set up and fully utilize
- Drag & drop functionality allows you to easily set up Gocator to work within your existing control system
- Intuitive control panels make setup fast and easy



Real time data visualizer

Real time sensor feedback

Choose the data acquired

Choose your trigger (time, encoder, external input or software)

Modify sensor settings for faster speeds

Control exposure to handle various surface types

Generate 3D surface from cross-section profile data

Set up how parts are detected and separated for volumetric measurement

ADVANCED CONNECTIVITY

Advanced connectivity makes Gocator quick to implement and cost effective.

Allows you to get the job done with the fewest components in the least amount of time.

- Onboard web server allows for fast setup on any computer
- Connect via industry standard Ethernet
- Simple cabling for inputs, outputs and power
- True standalone operation allows you to set up and walk away
- Modbus TCP, EtherNet/IP™, and simple ASCII string support for “plugging into” PLCs or robot controllers
- No hidden costs or additional hardware required

Can be wired to most existing controls with:

- Encoder
- Trigger Input
- Digital I/O
- Serial
- Analog
- Power

User PC (can be disconnected after setup for real standalone operation)

Power & Ethernet cordset (includes Laser Safety)

I/O cordset

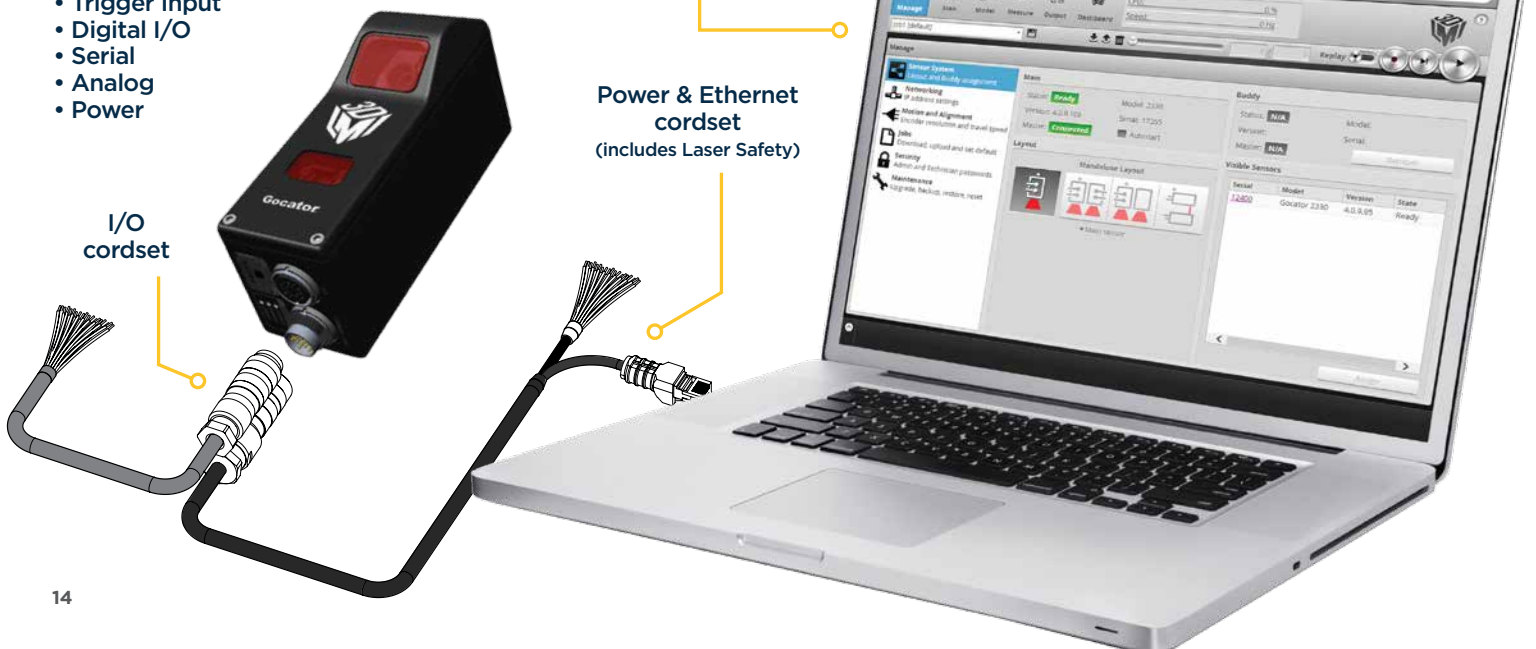

OPTIMAL EXPOSURE SETTINGS

Exposure is key to achieving optimal measurement results. Gocator sensors provide up to three exposure modes for scanning different types of target surfaces. Adjusting Gocator's exposure is as easy as dragging a slider.



OVER EXPOSURE

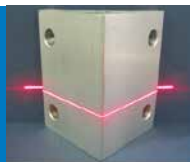

UNDER EXPOSURE



CORRECT EXPOSURE

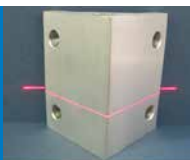

SINGLE EXPOSURE
Single Exposure is ideal for scanning parts with similar reflectivity.



DYNAMIC EXPOSURE
With Dynamic Exposure, Gocator adjusts exposure automatically between a min/max range to handle varying surface reflectivity between one scan and the next.



MULTIPLE EXPOSURE
Gocator creates a single laser profile from multiple exposure settings, making it easy to measure objects with both light and dark surfaces simultaneously.

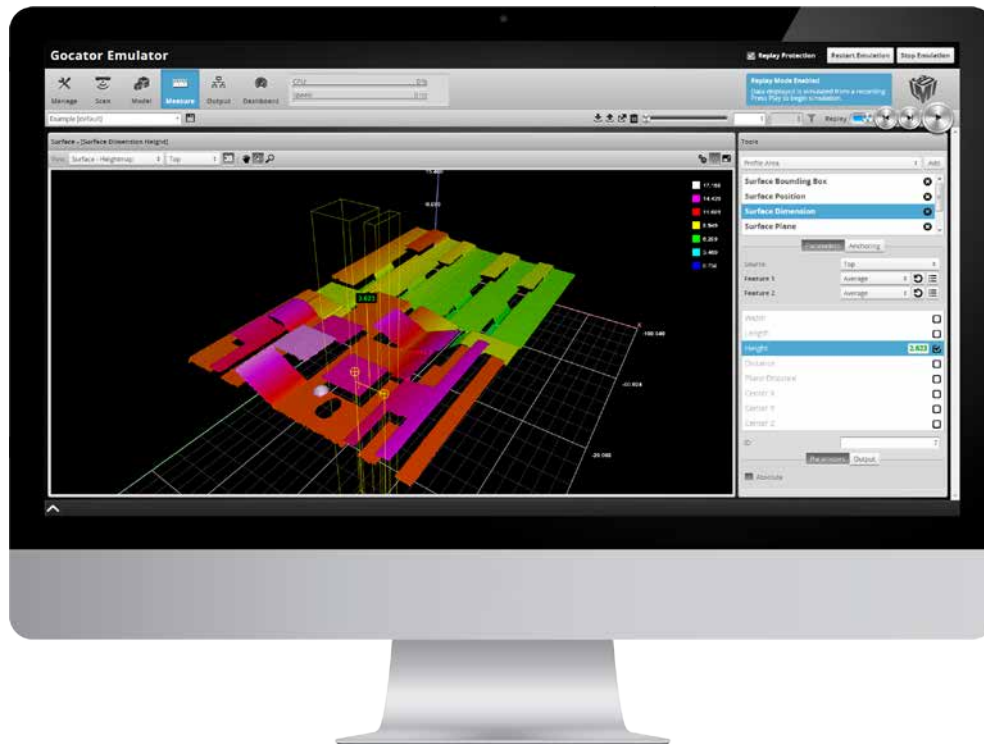

GOCATOR EMULATOR

The Gocator Emulator is a standalone application that allows you to run a “virtual” sensor using pre-recorded data without the need for a physical sensor.

Emulator supports SDK developers to create their applications using a virtual Gocator before real hardware is needed.

Did you know? Use Gocator to record live data without disrupting inline inspection performance. The recorded data can then be loaded into the Emulator for offline development and review.

- Use all the Gocator functionality, including measurement tools and part matching on recorded data—in a virtual web-based environment
- Analyze and create measurement solutions on data recorded from a real sensor in true production conditions
- Determine issues with current sensor configurations, then design and test improvements in a safe environment prior to deploying the solution on an actual sensor
- Develop fully integrated solutions in a stable offline environment
- Includes online version!



GOCATOR ACCELERATOR

The Gocator Accelerator (GoX) is a Windows PC application that allows you to add the data-processing power of one or more PCs to your inspection solution.

Setup is easy as selecting a Gocator for acceleration and launching a web browser session on your PC to perform local acquisition, measurement, and control.



- Increase processing speed and reduce cycle times
- Reduce cycle times
- Remove memory limitations
- Handle large 3D point clouds
- Configure and operate multiple networked Gocators

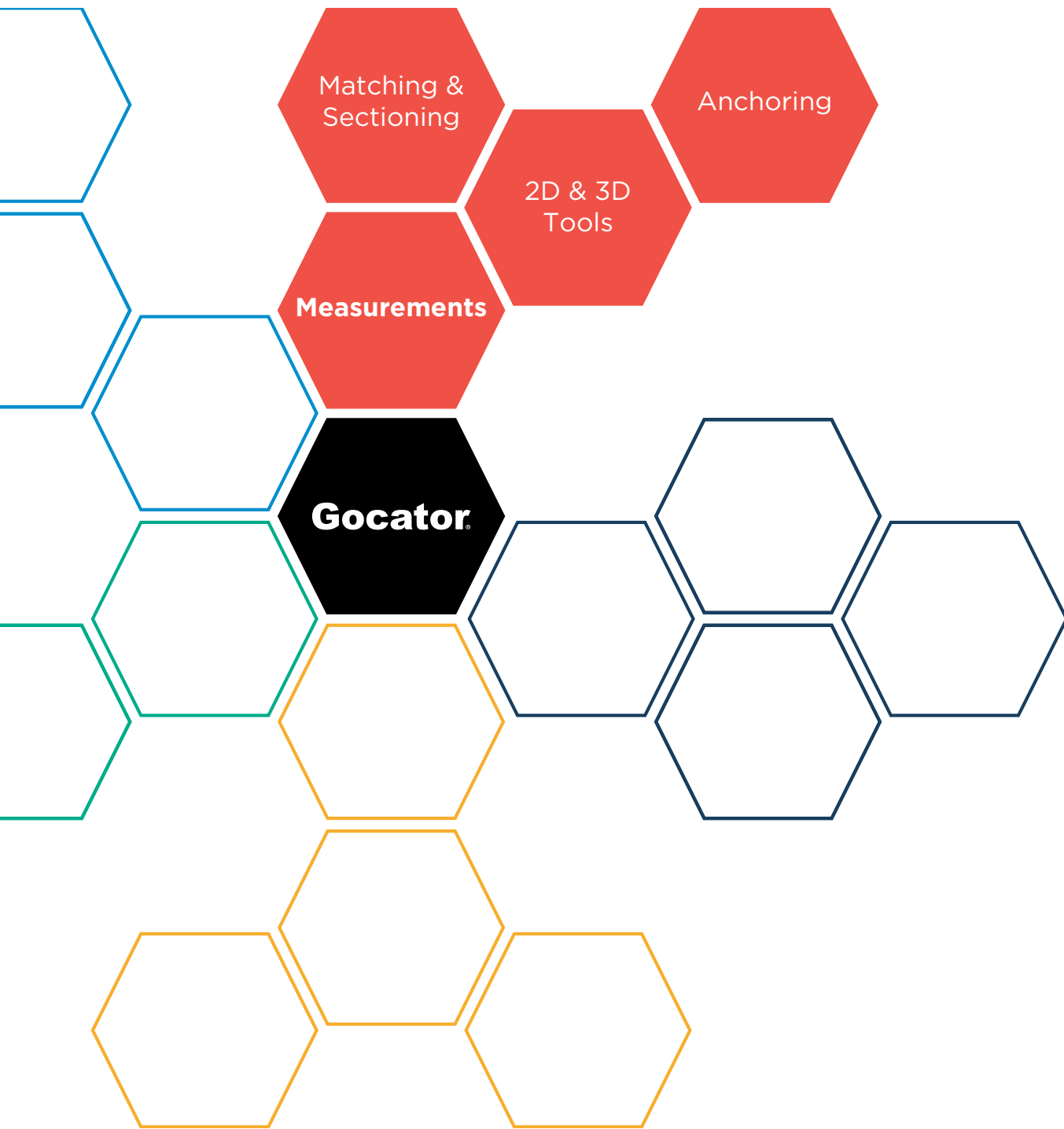

ROBUST MEASUREMENT

SPEED AND PRECISION

Measurement accuracy is critical to making correct pass/fail decisions and ensuring product quality and throughput.

- Powerful built-in tools turn 3D data into real-time measurements with pass/fail decisions
- Select the type of measurement and see live results with pass/fail limits
- Virtual anchoring maintains valid measurements by tracking part movement
- Record and playback features allow refinement of tolerances or export to CSV for later analysis
- Output filtering settings add extra stability to measurements
- All measurement tools can use combined 2D and 3D data

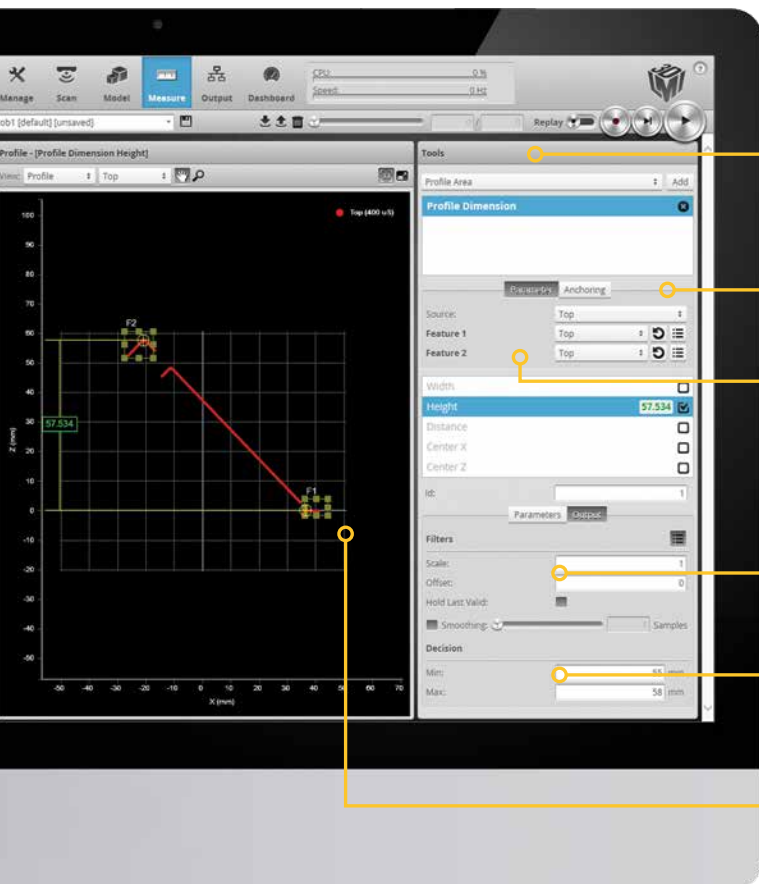

Choose your measurement tools

Enable anchoring to track part movement

Choose feature points to locate key measurements

Setup output filters to improve stability

Measure against minimum and maximum thresholds to quickly generate decisions

Resize and move search areas to easily select where and what to measure

POWERFUL BUILT-IN MEASUREMENT TOOLS

Gocator's built-in tools provide a full suite of measurement capabilities to solve a wide range of inspection challenges.

- No need for highly specialized knowledge, intensive training or writing of code. Just point, click and measure
- Write your own script to perform tailored calculations using measurement results
- Download firmware updates, for free, to access new Gocator functionality
- Extend Gocator measurement tools with your own measurement algorithms using the Gocator Development Kit (GDK). This industry first capability allows customers to develop and install their own intellectual property into standard Gocator's and is a significant addition to Gocator's smart sensor functionality.

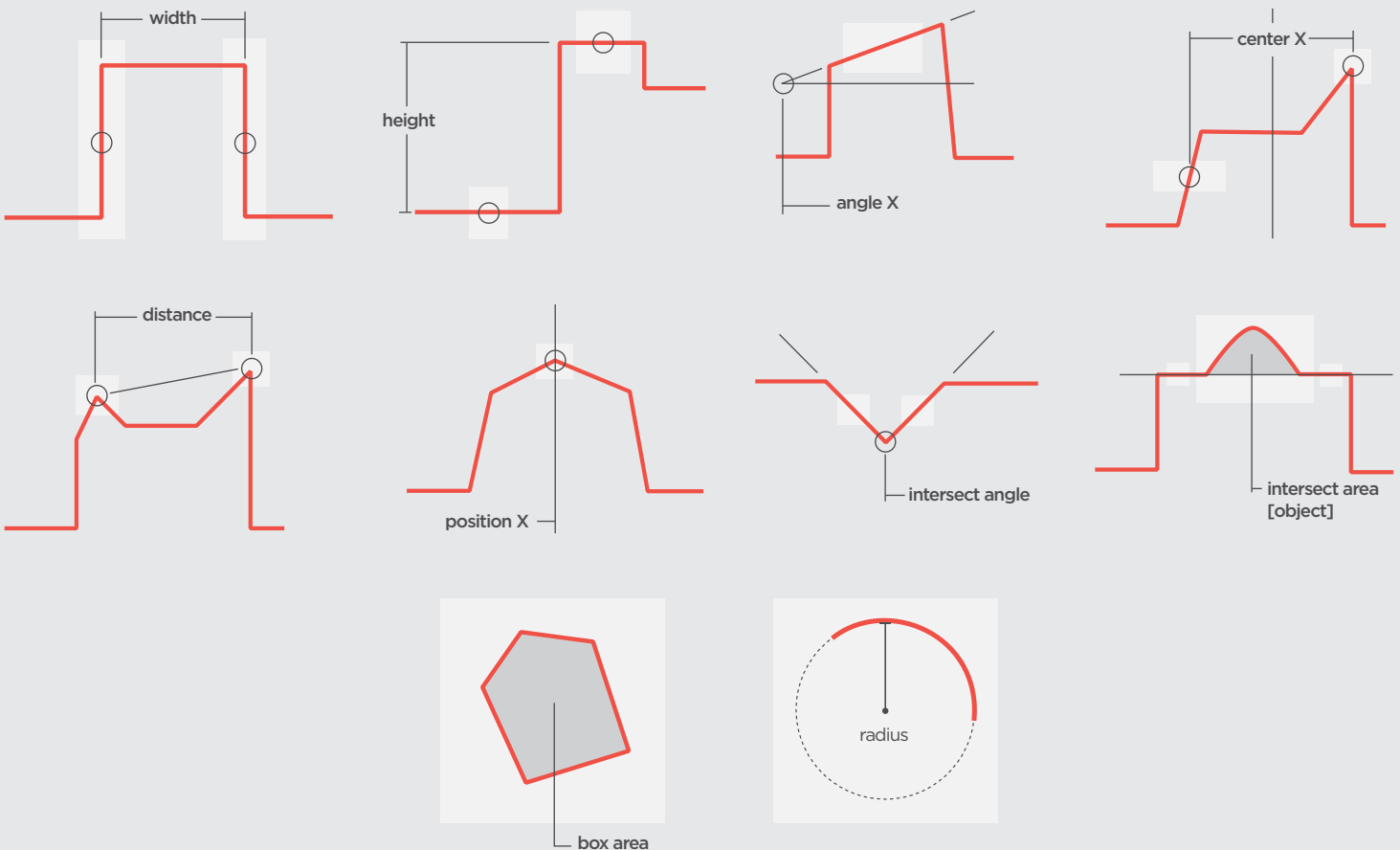

PROFILE MEASUREMENT

Gocator's profile tools detect and compare feature points or fit lines found within laser profile data. Measurement values are compared against minimum and maximum thresholds to yield accurate control decisions.

PANEL (GAP & FLUSH) TOOL

The panel tool automatically carries out gap and flush measurements. Gap measurement provides the distance between the edges of two surfaces, and flush measurement provides the flushness between the edges of two surfaces. This is a powerful tool used in the automotive industry.

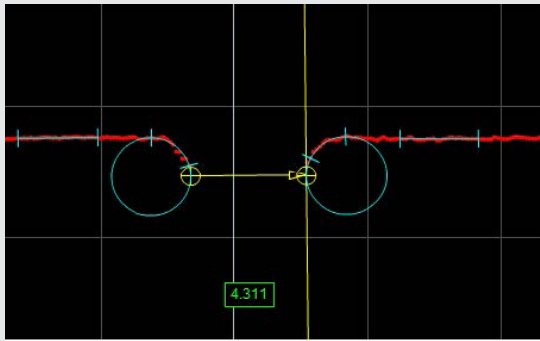

Measures the distance between two surfaces. The surface edges can be curved or sharp.

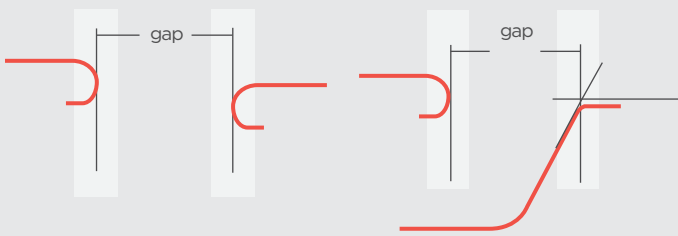

Measures the flushness between two surfaces. The surface edges can be curved or sharp.

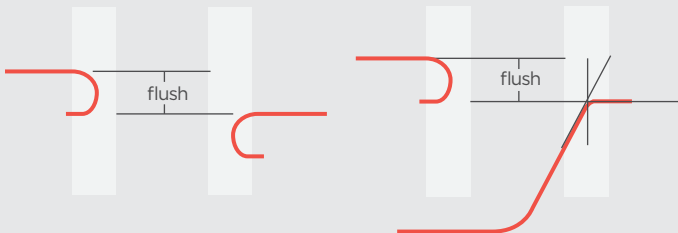

STRIP TOOL

A strip is a section of a profile with a distinct step height. The Strip tool measures the width of a strip, and lets you add multiple measurements of the same type to take data and set decisions for multiple strips. For example, if a rubber target has three strips, you can configure Gocator to measure the width of the first and the third strips using the same Strip tool.



Measures the width of a strip.



Measures the height of a strip.

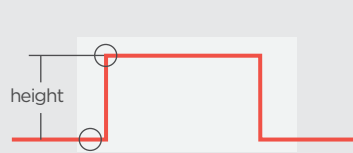

Measures the X and Z position of a strip.

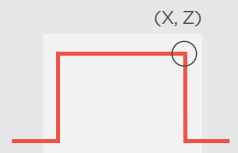
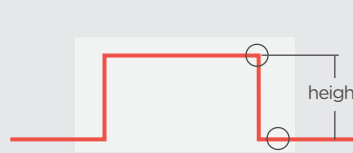
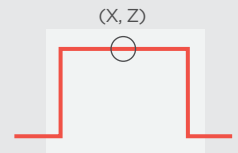
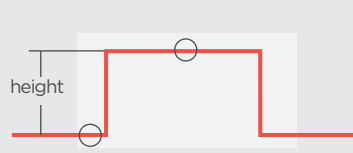
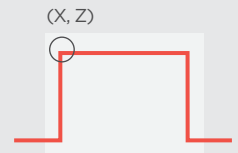

3D SURFACE MEASUREMENT

3D surface measurement involves measuring surface properties such as volume and height at a certain position. Gocator's volumetric tools have the ability to operate on the entire surface or the full object or within a region of interest at a given position in relation to the object's surface.

COUNTERSUNK HOLE TOOL

The countersunk hole tool automatically locates a countersunk circular opening on the object surface and provides measurements to evaluate its characteristics—including position (X, Y, and Z), outside radius, bevel angle and depth.

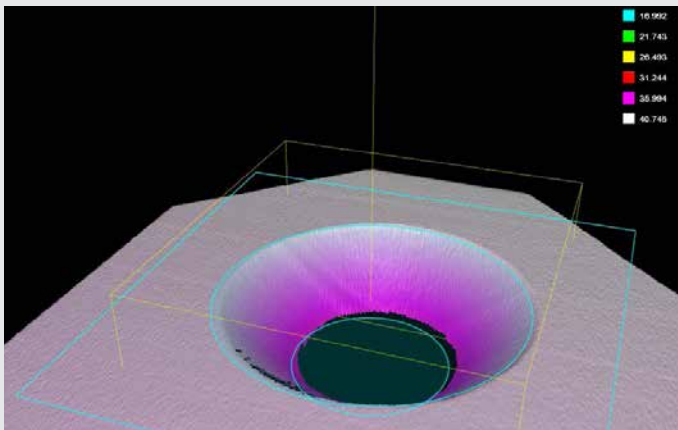

Determines the X, Y or Z position of the center of the countersunk hole.

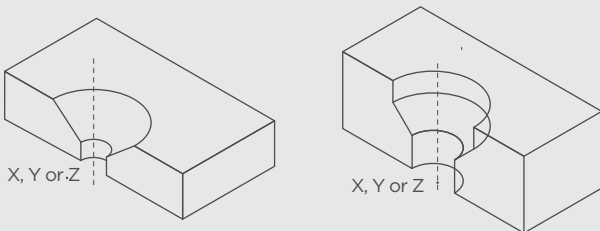

Determines the outer radius of the countersunk hole.

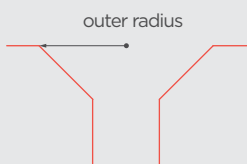

Determines the depth of the countersunk hole relative to the surface that the countersunk hole is on.

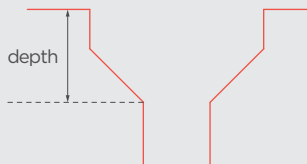
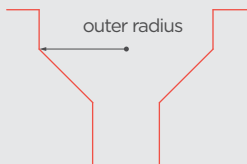

SURFACE PLANE TOOL

The Plane tool fits a region of points to a surface and calculates plane angles X and Y and offset Z from an alignment target. The results of the Plane Angle X and Plane Angle Y measurements can be used to customize the tilt angle in the Hole, Opening, and Stud tools.

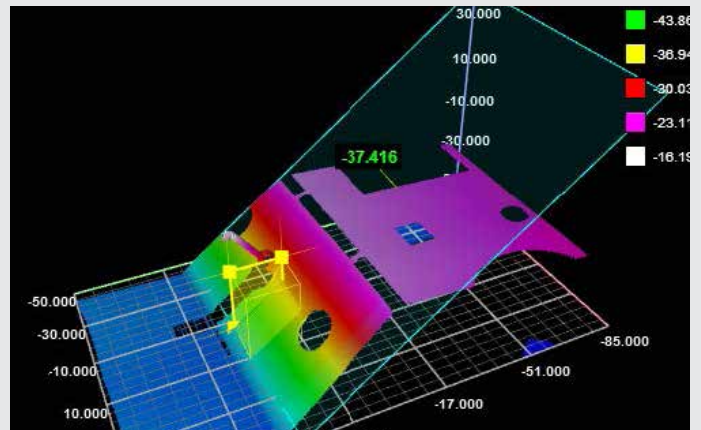

SMART MEASUREMENT FEATURES

Gocator's part matching, part sectioning and anchoring features provide maximum control and flexibility in your 3D measurement and inspection process.

PART MATCHING

Accurately inspect parts regardless of their orientation on the assembly line

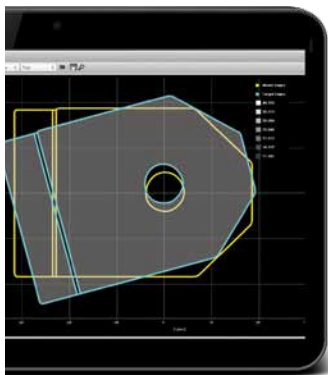

- Edge Matching capability automatically performs part realignment before applying Gocator's built-in measurement tools
- Eliminates the need to mechanically realign parts that are presented out of position
- Parts can move through the sensor's field of view in any rotation and Gocator will automatically re-align and inspect them

PART SECTIONING

Extract a cross-section from a 3D model of a part and perform advanced measurements

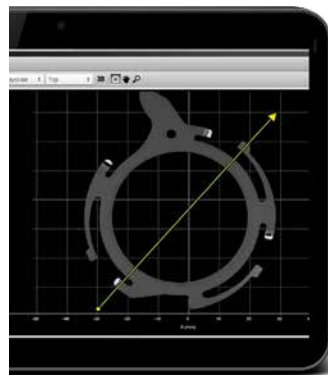

- Use profile tools on cross-sections of a Surface Mode scan
- Allows you to view the cross-section of a full 3D model
- Multiple sections can be added and positioned on a part
- Apply measurement tools to each individual section
- Ability to scan in surface mode to produce 3D shapes
- Allows you to see the cross-section of a full 3D model
- Ideal for determining and measuring cut lines

ANCHORING

Track the movement of parts within the field of view of the sensor and correct for variations in the height and position of parts

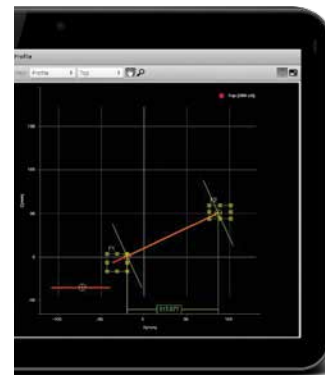

- Part movement is calculated as an offset from the position of a measured feature
- Correct the positions of measurement regions for other measurement tools
- Ensure the regions used to measure features are correctly positioned for every part
- Flexible anchoring supports multiple anchoring sources within the same setup
- Solve complex applications with part position and size variations
- No limit to the number of anchors used in an application

3D + 2D FUSION

Gocator combines 3D with 2D technology for a more robust inspection system.



INTENSITY OUTPUT (ACQUIRE INTENSITY)

Use one sensor to perform both 2D vision & 3D measurements

- Produces a calibrated, grayscale image from sensor light reflected off the part
- Easily integrate 2D image processing libraries to identify defects or patterns on a surface

HEXSIGHT

ROBUST 2D VISION LIBRARIES

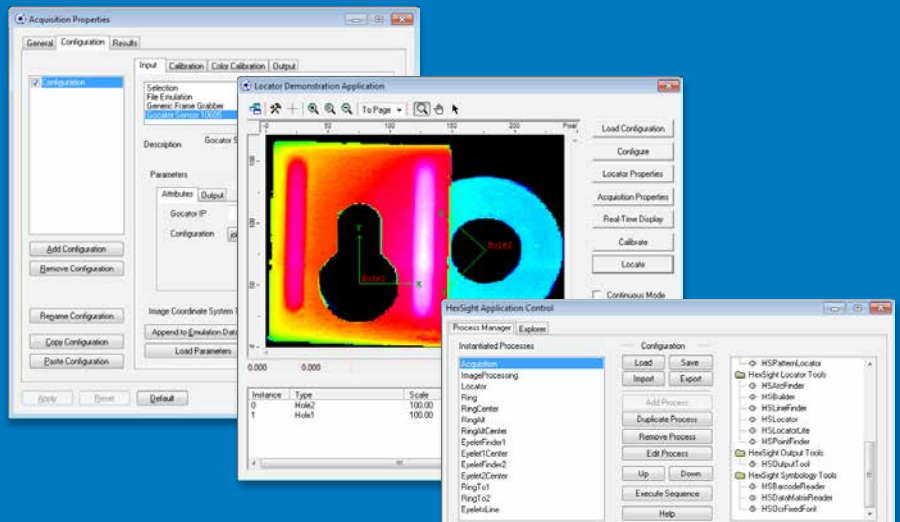

HIGH ACCURACY 2D PART LOCATION AND METROLOGY

HexSight geometric part location technology provides flexible and robust contour-based 2D pattern matching to locate parts and features regardless of their scale or orientation.

COMBINE 2D AND 3D FOR A MORE COMPLETE INSPECTION PROCESS

HexSight and Gocator work seamlessly together to create a more robust inspection system. With HexSight you can combine 3rd party machine vision camera images for 2D inspection with Gocator's 3D height maps for 3D measurement.

SEAMLESS INTEGRATION WITH GOCATOR

HexSight is tightly integrated with Gocator so acquisition of 3D point clouds and 2D intensity images can stream into inspection processing on a PC to produce results that are scheduled on Gocator hardware for output.

* Included at no cost with every Gocator 3D smart sensor.

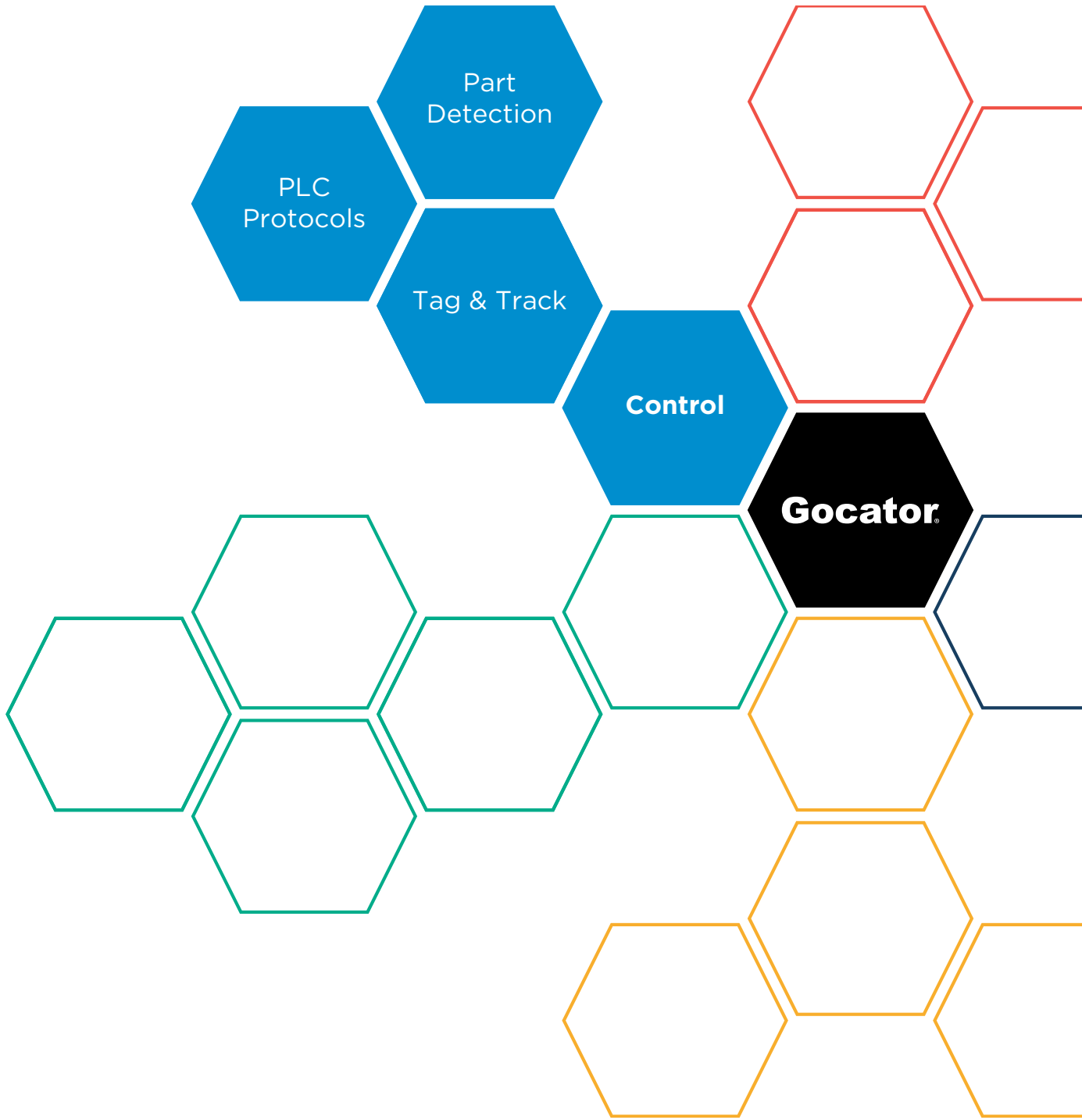

**MAXIMUM
CONTROL**

TRIGGER MODE

Triggers are “inputs” to the sensor that prompt the sensor to acquire data.

ENCODER + CONVEYOR

For profile measurements at a uniform spacing

TIME + CONVEYOR

For profile measurements at a fixed frequency

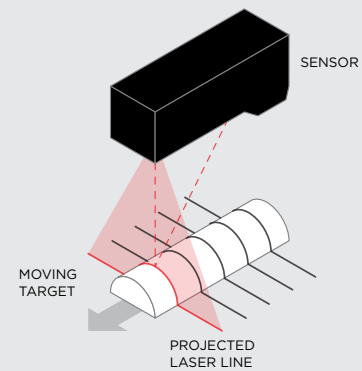
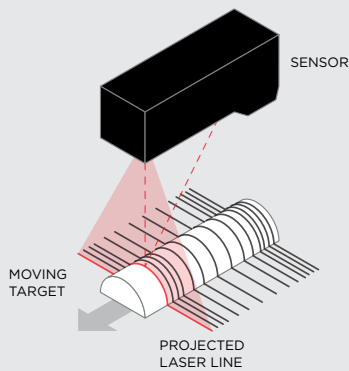

- An encoder can be connected to provide triggers in response to motion
- Encoder triggering is used with conveyors to perform profile measurements at a uniform spacing
- The speed of the conveyor can vary while the object is being measured; an encoder ensures that the measurement spacing is consistent, independent of conveyor speed
- Gocator supports three encoder triggering behaviors: track backward, ignore backward and bi-directional
- Gocators have an internal clock that can be used to generate fixed-frequency triggers
- The external input can be used to enable or disable time triggers
- Time triggering can be used instead of encoder triggering to perform profile measurements at a fixed frequency

Other Gocator triggers include:

- External Input
- Software

TOTAL SENSOR CONTROL

Gocator includes dedicated logic to support a number of sophisticated acquisition and part handling scenarios that are easy to setup and master.

PART DETECTION

Detect individual parts and build a 3D model ready for measurement

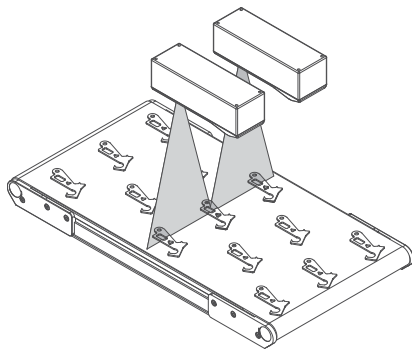

Detect and measure multiple discrete objects

- Save system cost and reduce complexity with Gocator's all-in-one whole part capability
- Auto detects and separates multiple parts appearing simultaneously
- Use gap filling to connect related parts into a single part

SURFACE GENERATION

Leverage a number of different methods to create a surface (height map)

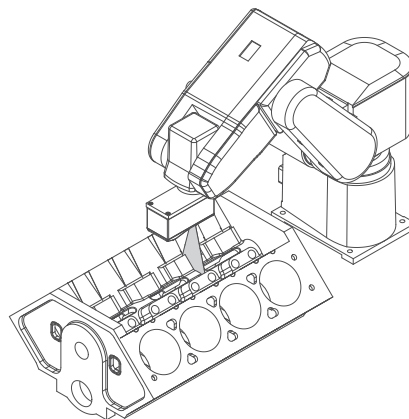

Example of Surface Generation: Variable Length

- Includes Continuous (Part Detection), Fixed Length (Sequential, External Input), Variable Length (External Input) and Rotational (Ticks per revolution, Z-index to re-order data)
- Provides greater control and flexibility for supporting common industry scanning methods such as conveyor, web, robotic, and rotational setups

PART EDGE FILTERING

Remove noise around the perimeter and interior of scanned surfaces or parts

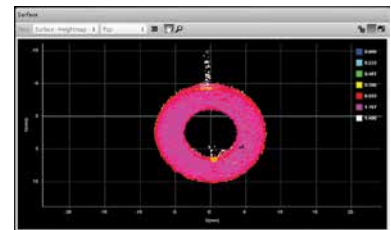

Edge Filtering disabled
(scan shows reflection noise)

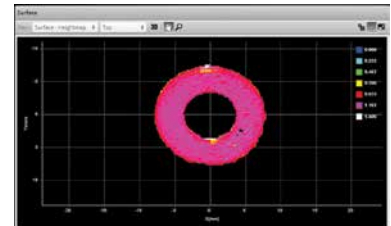

Edge Filtering enabled
(reflection noise eliminated or reduced)

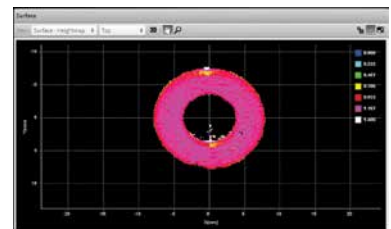

Edge Filtering enabled, Preserve Interior Feature enabled

- Noise filtering increases repeatability and accuracy of 3D measurements
- Allows measurement regions to be placed with high precision, without any noise interference

FLEXIBLE INPUT/OUTPUT

Output measurement results using Analog, Digital, Serial, or Ethernet methods including industry standard PLC protocols.

TAGGING & TRACKING

Tag and track parts to make precise and timely downstream control decisions

- Each part is tagged with a decision and tracked by its encoder position until the appropriate downstream location is reached
- The sensor then activates the appropriate control decision (e.g., sort, accept or reject via deflection gate) at the precise time
- Built-in control logic eliminates the unnecessary cost of adding PLC systems

Send profile and measurement information using binary, ASCII, and standard PLC protocols via Ethernet

Control simple external devices with digital outputs

Convert measurement values and decisions to analog output signals

Transmit data and decisions via RS-485 serial output channel

The diagram features a computer monitor displaying the Gocator software interface. The interface includes a top navigation bar with 'Manage', 'Scan', 'Model', 'Measure', 'Output', and 'Dashboard' tabs. Below this, there's a 'job1 [default] [unsaved]' dropdown and a 'Speed' control. The main area is titled 'Output' and contains a list of protocols: 'Ethernet', 'Digital 1', 'Digital 2', 'Analog', and 'Serial'. Each protocol has a brief description of its capabilities. To the right of this list is an 'Information' section with a 'Protocol: Gocator' dropdown and a text area explaining the Gocator Protocol's use of TCP messages. At the bottom of the diagram, the Modbus and EtherNet/IP logos are displayed.

MORE WAYS TO CONTROL YOUR DATA

Gocator gives you the flexibility to simultaneously output data and decisions to a wide variety of I/O. It also allows you to easily communicate with your existing hardware including PLCs and robot controllers via Modbus TCP, EtherNet/IP™ or custom ASCII strings.

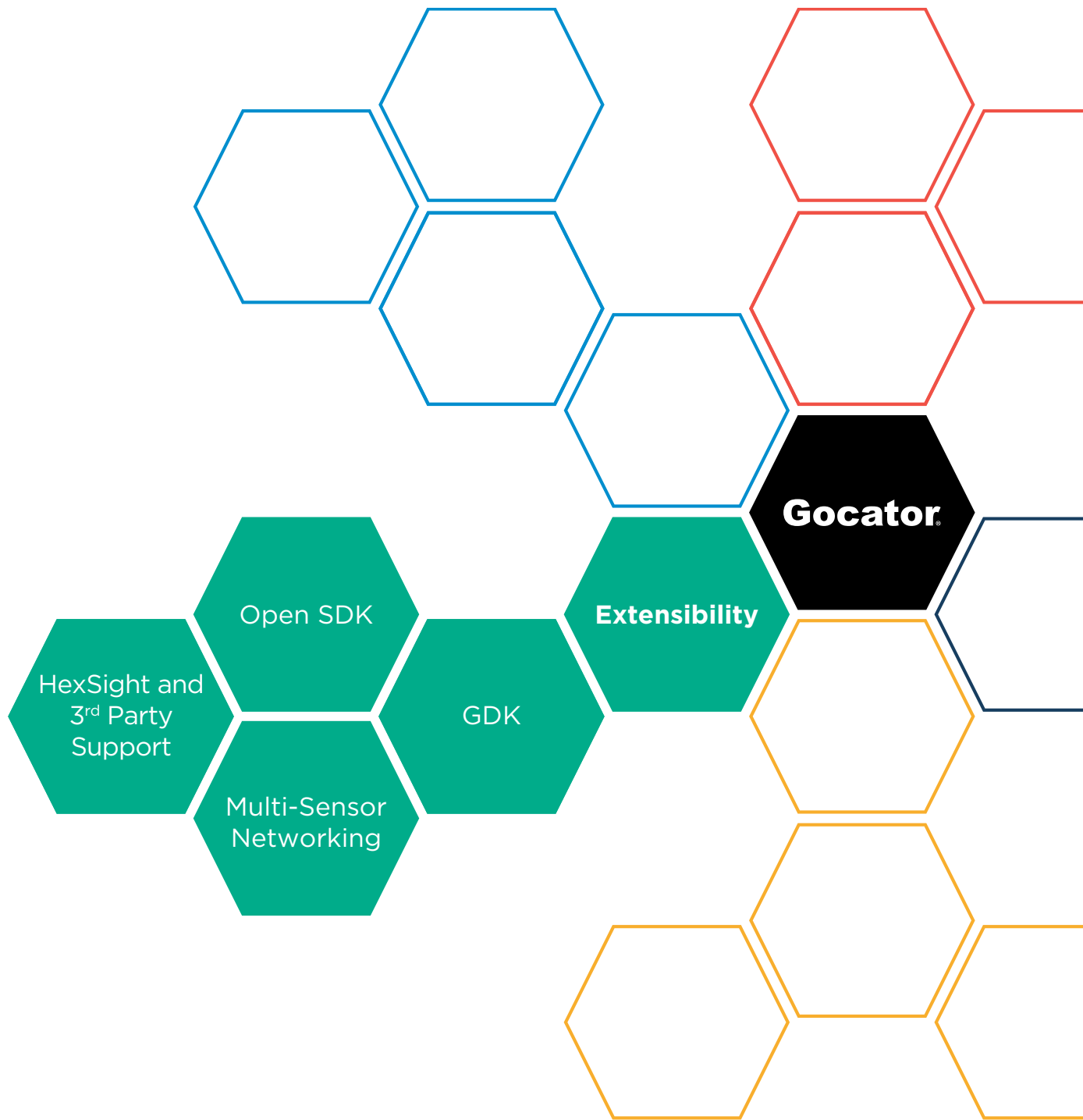

REVOLUTIONARY **EXTENSIBILITY**

DUAL SENSOR SYSTEMS

Easily create a dual sensor system to increase 3D scan coverage.

- Gocator automatically recognizes a second sensor called a “Buddy”
- Dual sensor mode seamlessly combines profile data from both Main and Buddy sensors as if they were one
- Dual Sensor Systems use a single GUI to configure, measure, make decisions and show results



WIDE ORIENTATION

Mount a Main (left) with a Buddy (right) to measure objects that are wider than a single sensor's field of view. Sensors can be angled to avoid occlusions



OPPOSITE ORIENTATION

The Main and Buddy perform top and bottom differential measurements to calculate true thickness when the object cannot be referenced to a known surface such as a conveyor.

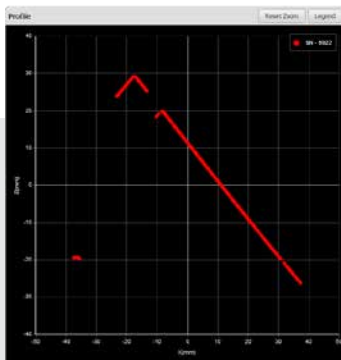

MAIN

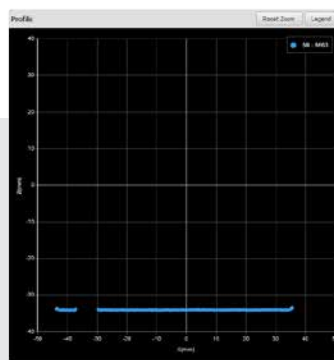

BUDDY

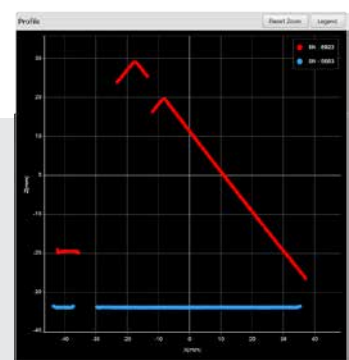

COMBINED

MULTI-SENSOR NETWORKING

When an application calls for more than a dual sensor system, multiple sensors can be networked using an LMI Master Hub.

- The Master product line offers models that support 4, 8, 12, or 24 Gocator connections
- Masters provide power, laser safety and distributed synchronization (time, encoder, external trigger)
- Each Gocator transmits 3D profile data to the host computer through standard Ethernet switches
- Use Gocator Accelerator to simplify the setup and alignment of multi-sensor systems and speed up point cloud processing from multiple sensors

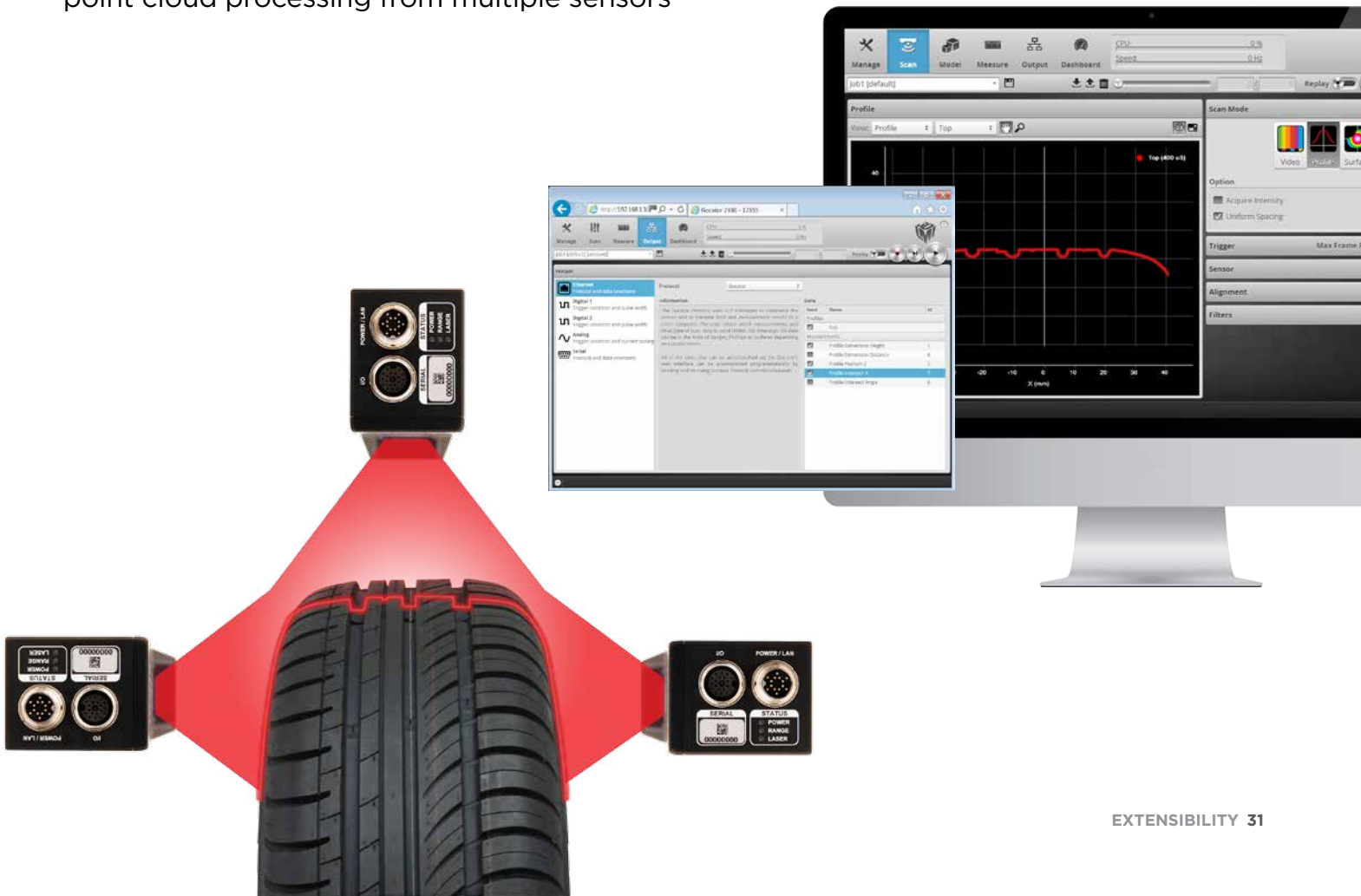
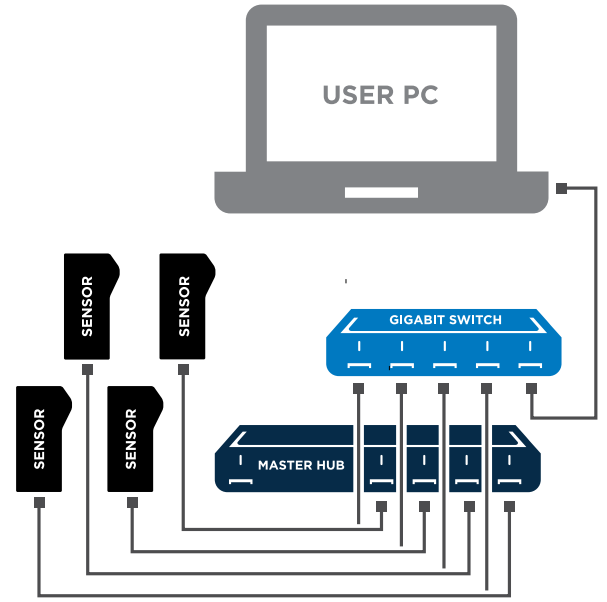

EXTENDED CAPABILITIES

Benefit from features that extend Gocator's functionality and allow you to customize your sensor to meet specific application requirements.

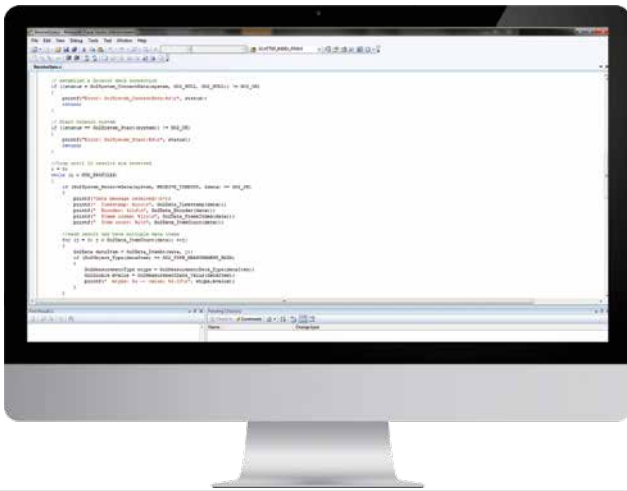

OPEN SOURCE SDK

- A single C-based SDK to control, acquire and manage any Gocator
- Unified library for all Gocator technologies - learn it once and use it everywhere
- Compile and execute on any target environment

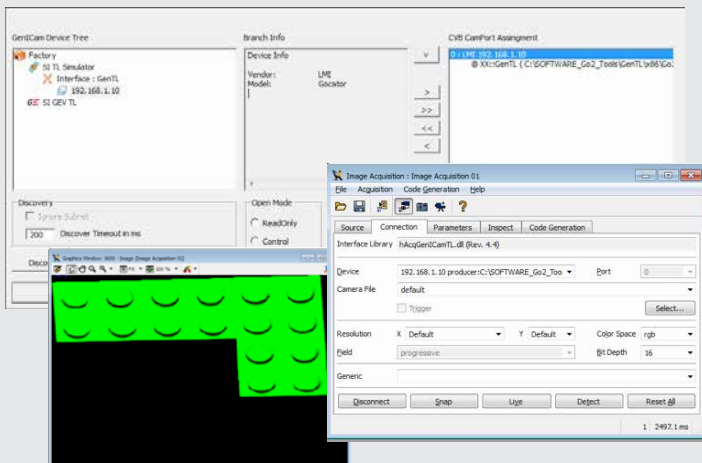

GENICAM TRANSPORT LAYER

- Real-time streaming of 3D data from Gocator to PC applications for external image processing
- GenTL driver support allows Gocator to interface with any application that supports GenICam, including Halcon CVB



NATIVE DRIVERS

- Real-time streaming of 3D data from Gocator to HexSight and NI LabVIEW
- Export 3D data from Gocator in CSV or ASCII format

GDK

(GOCATOR DEVELOPMENT KIT)

The GDK allows for custom development of your own measurement algorithms that run directly on Gocator sensors, transforming an off-the-shelf sensor into a fully customized device based on specific application needs.

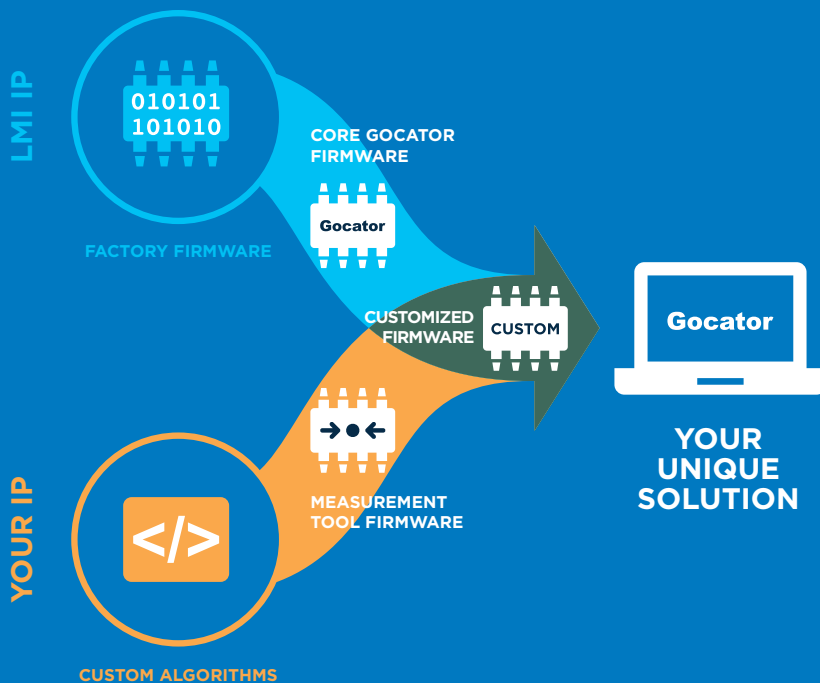

THE GOCATOR DEVELOPMENT KIT (GDK) is a powerful platform providing extensibility to the Gocator Firmware.

- Extend your existing set of measurement tools and make specialized measurements for applications with unique requirements while protecting your IP
- Produce optimized custom firmware builds that run within the realtime OS of the Gocator
- Use custom solutions on a variety of different sensors, all on a single platform
- Run your customized measurement tools in the Gocator Emulator for offline development, testing, and support of Gocator outputs such as analog, digital, Ethernet and PLC protocols
- Run your customized measurement tools in the Gocator Emulator

NOW THAT'S SMART.

THE LMI ADVANTAGE

What makes LMI different from catalogue-based companies is that **our sole focus is 3D technology**. Four pillars support this specialized approach and drive our commitment to accelerate customer profitability by delivering the highest performing and most cost-effective 3D scanning and inspection solutions.

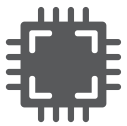

Chip Level Engineering

We design and deliver proven 3D technologies at the lowest cost.



Smart Technology

Smart sensors run standalone to produce inspection solutions out-of-the-box.



Simple User Experience

You don't need to be a rocket scientist to use our products—just point and click.



Progressive Partnerships

We build OEM solutions in support of our long term partnerships.

“ LMI provides OEMs with a flexible 3D technology platform that can be customized to meet their unique business demands. Unlike our competitors, 3D scanning and inspection is all we do, and it is this specialized knowledge and experience that helps drive profitability, reduce time to market, and open up new possibilities for our clients.

TERRY ARDEN, CEO



AMERICAS

LMI Technologies Inc.
Burnaby, BC, Canada

EMEAR

LMI Technologies GmbH
Teltow/Berlin, Germany

ASIA PACIFIC

LMI (Shanghai) Trading Co., Ltd.
Shanghai, China



LMI Technologies has offices worldwide. All contact information is listed at lmi3d.com/contact