

FLEXTRAC SERIES CATALOG

Plastic Chain Options

- 

Plain Chain — Available in White POM, Black Anti-static, Yellow POM-Kevlar
- 

Friction Chain — Available in White POM, Black Anti-static, and Yellow POM-Kevlar
- 

Molded Friction Chain — Available in White PP
Friction material: Gray TPE
- 

Flocked Chain — Available in White POM
Flock color: Grey
- 

Cleated Chain — Available in White POM, Black Anti-static, Yellow POM-Kevlar
Cleat height: 15mm
- 

Roller Cleated Chain — Available in White POM
Roller height: 50mm
- 

Finger Gripper Chain — Available in White POM, Black Anti-static, Yellow POM-Kevlar
Gripper height: 13mm
- 

Box Gripper Chain — Available in White POM, Black Anti-static, Yellow POM-Kevlar
Gripper height: 26mm
- 

Wedge Gripper Chain — Available in White POM, Black Anti-static, Yellow POM-Kevlar
Gripper height: 27mm

Note: Not all chain options are available for all widths. Please consult factory for more information.

Chain Widths & Conveyor Codes

Flextrac Series conveyor models are categorized by the width of the plastic chain on the conveyor system.

Chain Width	Code	
63mm (2.5")	MS2	
83mm (3.3")	MM3	
140mm (5.5")	ML2	
220mm (8.7")	MX2	
315mm (12.4")	MT2	
435mm (17.1")	MR2	
585mm (23.0")	MF2	

PLASTIC CHAIN TECHNOLOGY BY



Guide Rails
Adjustable to contain and guide any product

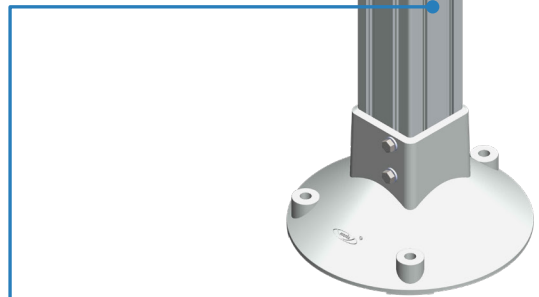

Supports
A wide variety of support options are available

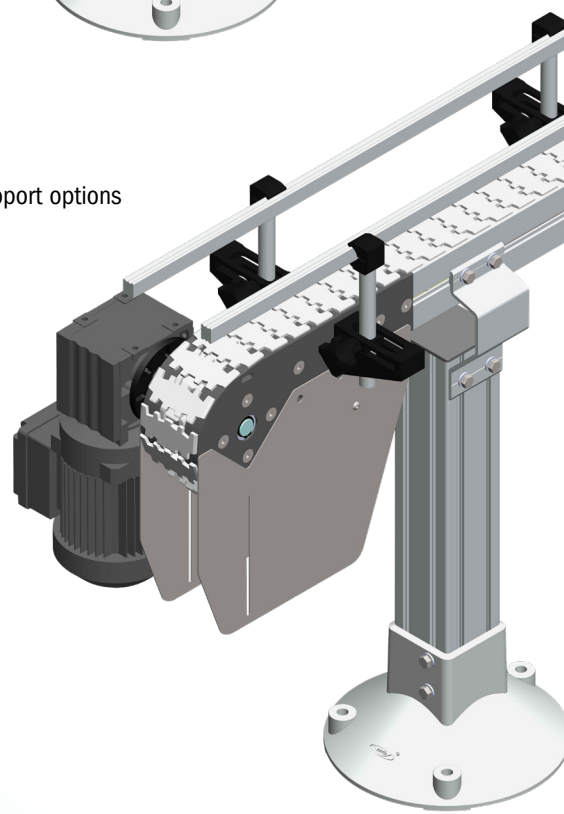

Modular Plastic Chain Conveyors

Flextrac Series modular plastic chain conveyors fit the curves and elevation changes of your plant with modular components that are easy to configure and integrate. Multiple curves, inclines and declines can be included in a single conveyor.

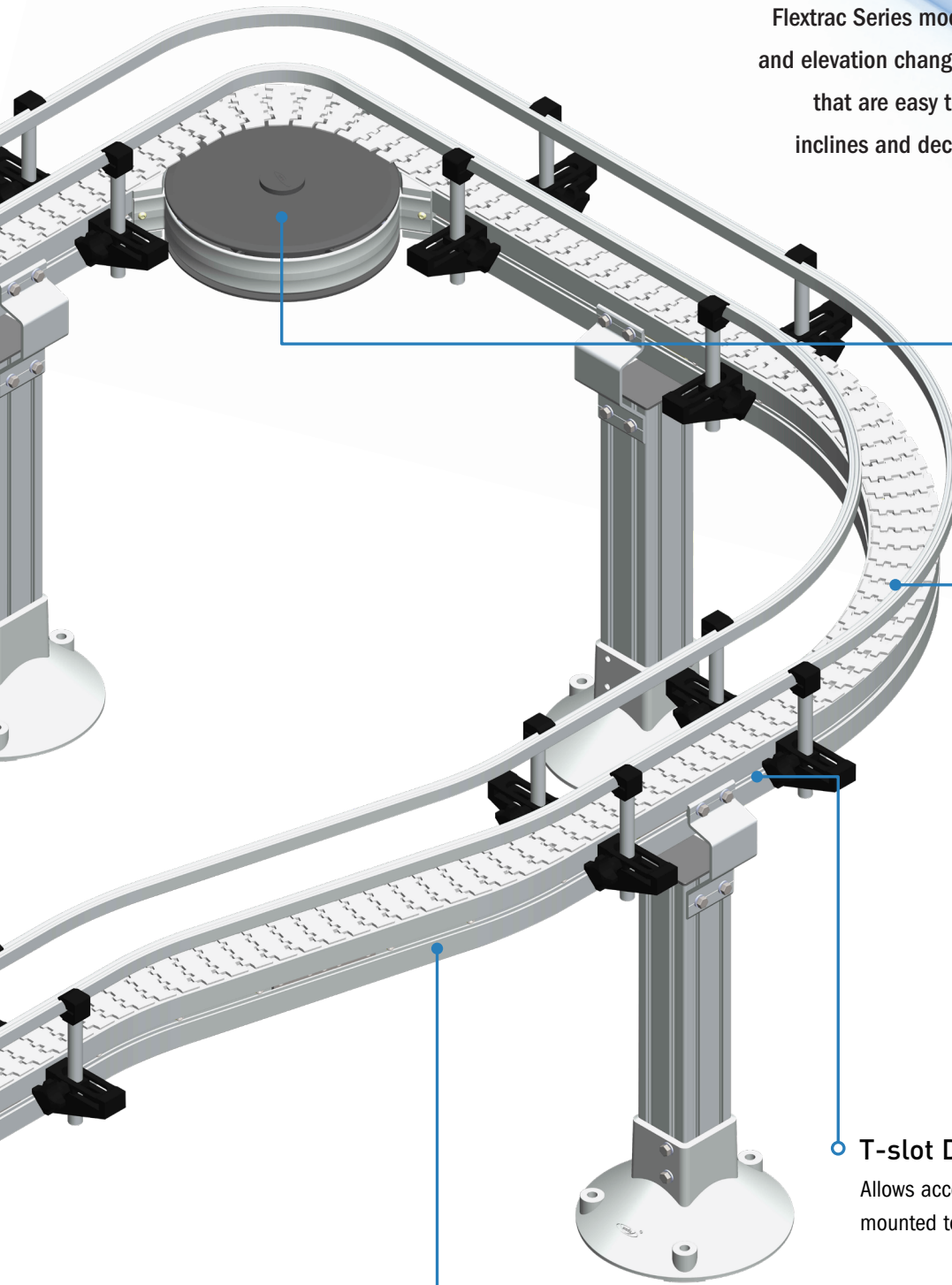

Wheel Bends

Reduce friction and allow a tighter radius at turns

Plain Bends

Simple turns available in a wide variety of angles

T-slot Design

Allows accessories to be easily mounted to conveyor

Vertical Bends

Allow elevation changes to smoothly lower or elevate product

Drive Units & Idler Ends

Front Drive

Side mounted conveyor drive end



Idler End

Non-driven conveyor tail end

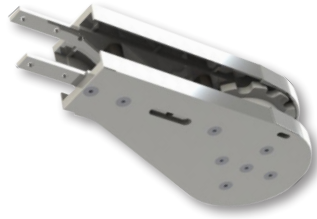

Width Compatibility

MS2	63mm (2.5")	✓
MM3	83mm (3.3")	✓
ML2	140mm (5.5")	✓
MX2	220mm (8.7")	✓
MT2	315mm (12.1")	✓
MR2	435mm (17.1")	✓
MF2	585mm (23.0")	✓

Intermediate Drive

Frame mounted center drive unit for applications where both ends of the conveyor need to be clear



Suspended Drive

End drive unit that allows the motor to sit underneath the conveyor, reducing the overall width of the drive end



Width Compatibility

MS2	63mm (2.5")	✓
MM3	83mm (3.3")	✓
ML2	140mm (5.5")	✓
MX2	220mm (8.7")	—
MT2	315mm (12.1")	—
MR2	435mm (17.1")	—
MF2	585mm (23.0")	—

Free Transfer Roller

Free moving rollers which support product as it is transferred through various stages of the system.

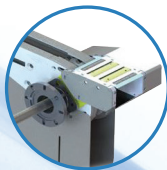

Driven Transfer Roller

Driven rollers support the product as it is transferred through the system. Driven transfer roller speed is approximately 10% higher than the conveyor speed.



DRIVE ORIENTATION QUICK GUIDE

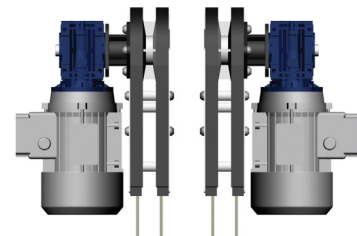

Left ↑ ↑ Right

Gearmotor sold separately

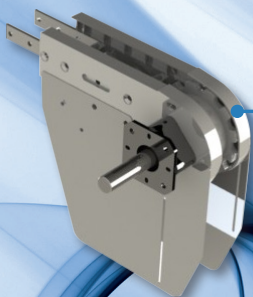

Horizontal Wheel Bend

Wheel bends use a free-spinning wheel to reduce friction in a turn. They are the preferred method for turns.

IQS Angles: 30°, 45°, 60°, 90°, 180°

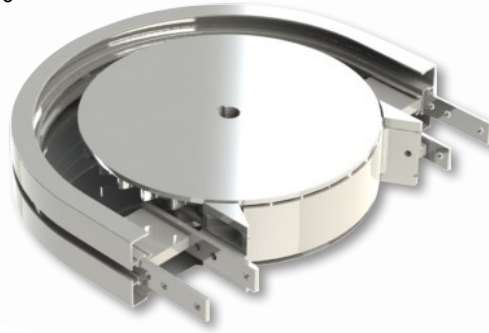

Width Compatibility

MS2	63mm (2.5")	✓
MM3	83mm (3.3")	✓
ML2	140mm (5.5")	✓
MX2	220mm (8.7")	—
MT2	315mm (12.1")	—
MR2	435mm (17.1")	—
MF2	585mm (23.0")	—

Horizontal Plain Bend

Plain bends allow turns with a larger radius. On conveyors where multiple plain bends are used, the total of all angles cannot exceed 180°.

IQS Angles: 90°

Additional Angles: 30°, 45°, 60°



Width Compatibility

MS2	63mm (2.5")	✓
MM3	83mm (3.3")	✓
ML2	140mm (5.5")	✓
MX2	220mm (8.7")	✓
MT2	315mm (12.1")	✓
MR2	435mm (17.1")	✓
MF2	585mm (23.0")	✓

Vertical Plain Bend

Vertical plain bends allow product to be elevated or lowered while being conveyed. On conveyors where multiple plain bends are used, the total of all angles cannot exceed 180°.

IQS Angles: 5°, 7°, 15°, 25°, 30°

Additional Angles: 45°, 90°



Width Compatibility

MS2	63mm (2.5")	✓
MM3	83mm (3.3")	✓
ML2	140mm (5.5")	✓
MX2	220mm (8.7")	✓
MT2*	315mm (12.1")	✓
MR2*	435mm (17.1")	✓
MF2*	585mm (23.0")	✓

*Angles up to 25°

Guides & Supports

Guide and stand configurations are available to fit any application.

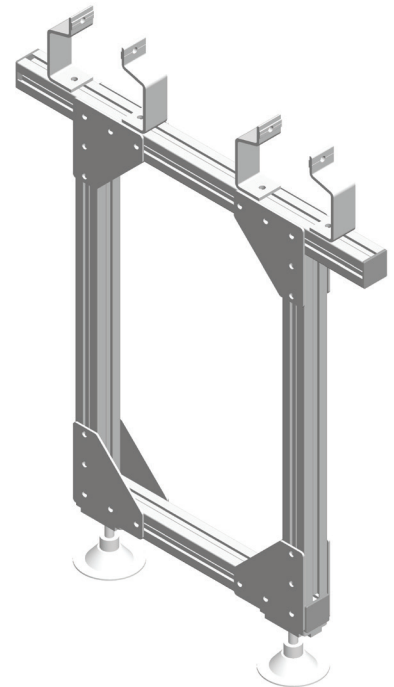
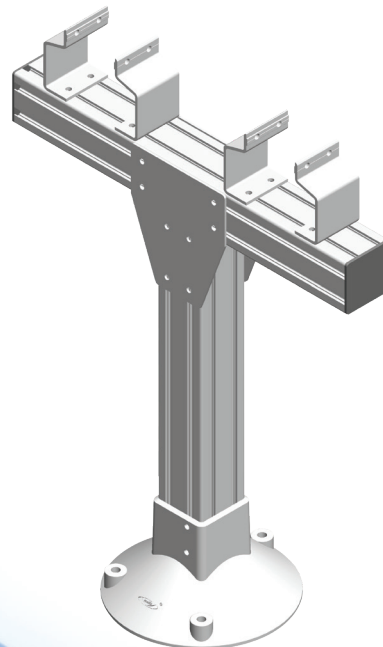
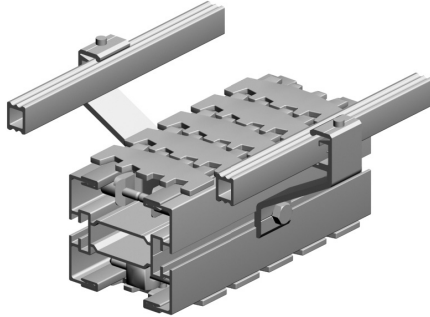
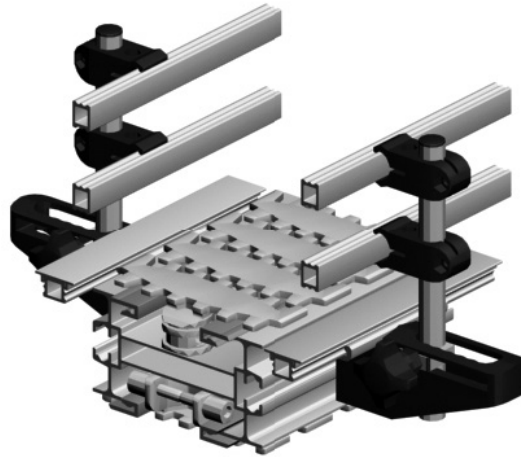
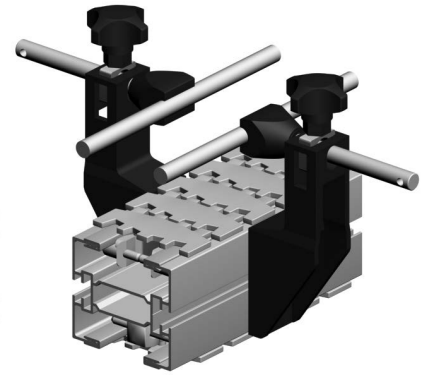
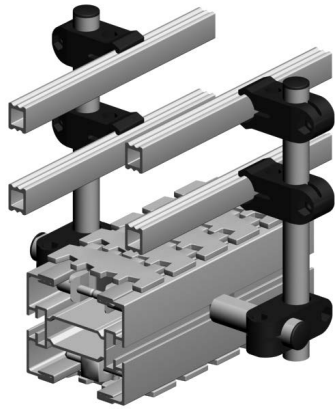
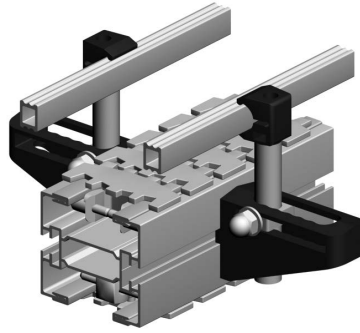
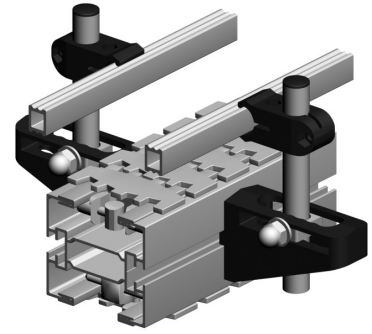

Alpines & Gripper Elevators

Alpine Conveyors

Used as a space-saving accumulation zone or for cooling/drying product. They can also be used in an offline capacity to hold product during changeovers or machinery breakdowns.

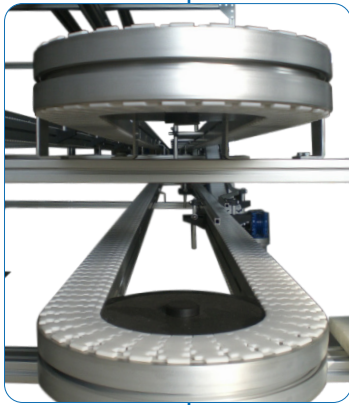

Gripper Elevator

The product is gripped between two conveyors and elevated or lowered to a different level of your plant, over an aisle or to remove product from a puck.

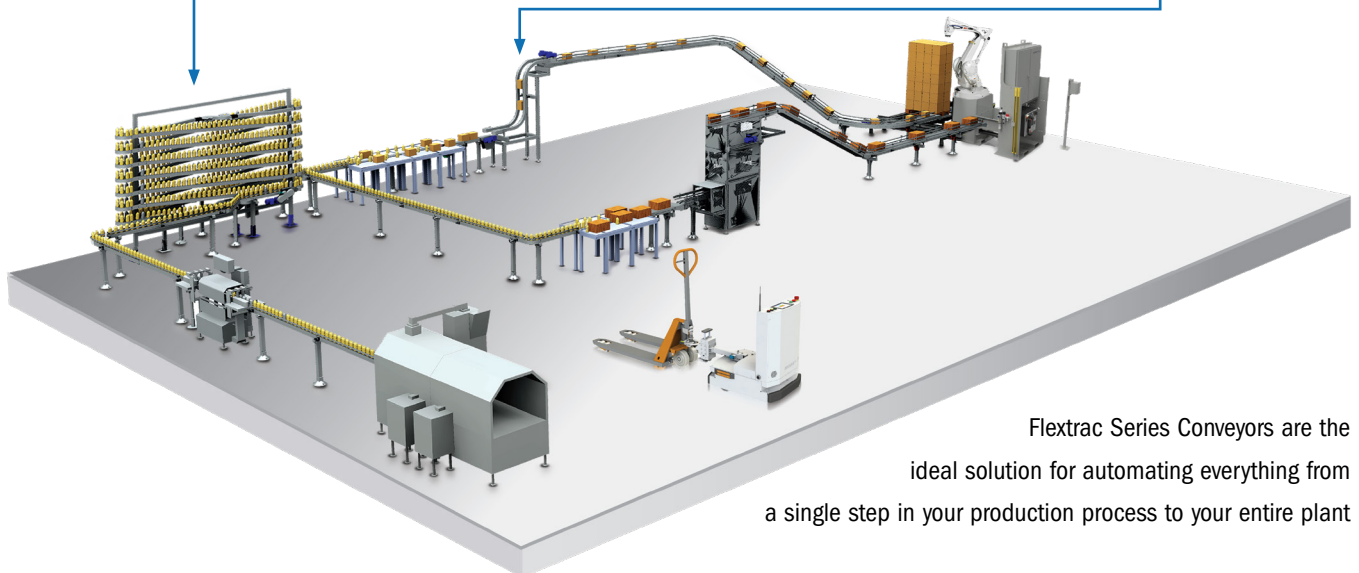
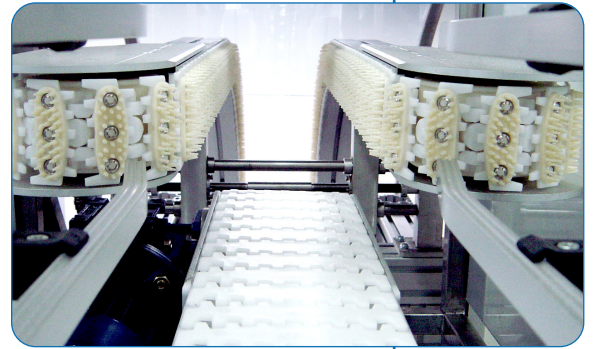
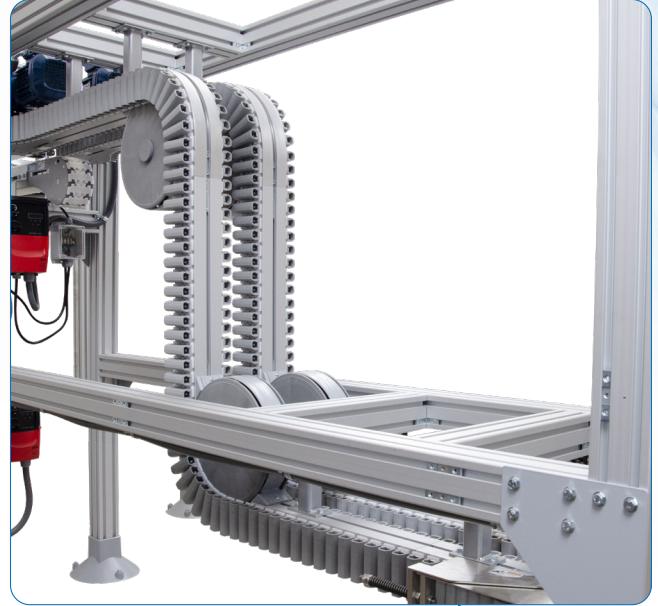

Flextrac Series Conveyors are the ideal solution for automating everything from a single step in your production process to your entire plant

Learn More

Additional Products Available from QC Conveyors®

In addition to our versatile **Flextrac Series** conveyors, we offer a variety of other products. **Automation Series** conveyors are built on a rigid aluminum frame with features designed for ease of use, while **HydroClean Series** conveyors feature an easy-to-clean sanitary design. Our **Industrial Series** includes IS125 conveyors built for heavier loads, IS175-ID conveyors with an embedded drive, and IS300 conveyors which feature a timing belt with accuracy to $\pm .015"$. Please visit our website or contact your local distributor for more information.



qcconveyors.com

QC Conveyors' website — qcconveyors.com — is your resource for the most up-to-date information about all our products.



Your Local Distributor

Contact us today at (513) 753-6000 to find your local distributor.

FLEXTRAC SERIES CATALOG



(513) 753-6000 | qcconveyors.com | Part # MKTG-FT-2001



QC CONVEYORS IS A MEMBER OF THE DURAVANT FAMILY OF COMPANIES

PACKAGING SOLUTIONS | PROCESSING SOLUTIONS | MATERIAL HANDLING SOLUTIONS | SUPPORTPRO

www.duravant.com